



LP Conversion Instructions

FG7TC Series

Two-Stage Condensing and Non-Condensing Furnaces
with Fixed Speed and Variable Speed Blowers

CONDENSING GAS FURNACES (UP TO 95% AFUE)



FG7TC-1 Upflow / Horizontal Furnace

Gas Valve Model VR9205Q - Ecoer Part Number 921691

Sprint Kit Part Number 50033841-005

ORIFICE PKG #55

FURNACE MODEL	INPUT	ALTITUDE ABOVE SEA LEVEL											
		0 to 1,999 FT		2,000 to 2,999 FT		3,000 to 4,999 FT		5,000 to 5,999 FT		6,000 to 7,999 FT		8,000 to 10,000 FT	
		ORIFICE SIZE	MANIFOLD PRESSURE	ORIFICE SIZE	MANIFOLD PRESSURE	ORIFICE SIZE	MANIFOLD PRESSURE	ORIFICE SIZE	MANIFOLD PRESSURE	ORIFICE SIZE	MANIFOLD PRESSURE	ORIFICE SIZE	MANIFOLD PRESSURE
*G7TC/*GC2TC *G7TL/*GC2TL	60,000	55	10.0	55	9.0	55	8.5	56	10.0	56	9.0	56	8.5
	80,000	55	10.0	55	9.0	55	8.5	56	10.0	56	9.0	56	8.5
	100,000	55	10.0	55	9.0	55	8.5	56	10.0	56	9.0	56	8.5
	120,000	55	10.0	55	9.0	55	8.5	56	10.0	56	9.0	56	8.5
	Low Fire		4.2		3.8		3.6		4.2		3.8		3.6

CONVERTING TO LP/PROPANE GAS AT ALTITUDES BETWEEN ZERO & 10,000 FT.

Converting single stage valves to LP/Propane requires the replacement of the burner orifices and/or the spring found under the cap screw in the pressure regulator. Converting 2 - stage valves to LP/Propane requires the replacement of the burner orifices and/or the stem/spring assembly in the pressure regulator.

Table 2 (page 3), provides the manifold pressure for altitudes above 2,000 feet.

WARNING:

Shut off the gas supply at the manual gas shutoff valve, before disconnecting the electrical power. A fire or explosion may result causing property damage, personal injury or loss of life. Failure to follow the safety warnings exactly could result in serious injury, death or property damage.

WARNING:

To avoid electric shock, personal injury, or death, turn off the electric power at the disconnect or the main service panel before making any electrical connections.

WARNING:

The reduction of input rating necessary for high altitude installation may only be accomplished with factory supplied orifices. Do not attempt to drill out orifices in the field. Improperly drilled orifices may cause fire, explosion, carbon monoxide poisoning, personal injury or death.

Before You Convert the Gas Valve

1. Turn the thermostat OFF or to its lowest temperature setting.
2. Verify the gas supply is shut OFF.
3. Verify the electrical power to the appliance is turned OFF.

Removing The Burner Orifices

1. Set the thermostat to the OFF position, or its lowest temperature setting.
2. Shut OFF the gas supply at the manual shutoff valve located outside of the appliance.
3. Turn off all electrical power to the appliance.
4. Remove the door from the burner compartment.
5. Move the gas valve ON/OFF switch (4) to the OFF position as shown in Figure 1. For VR8205Q2381 gas valves, turn the knob to the OFF position.

6. Remove the wires from the terminals (3) of the gas valve (6).
7. Remove the supply gas piping from the gas valve inlet (5).
8. Carefully remove four screws (8) securing the gas manifold assembly (7) to the burner assembly (9).
9. Set the screws (8) aside and remove the gas manifold assembly (7) from the appliance.
10. Carefully remove the burner orifices (2) from the gas manifold assembly (7).
11. Read the rating plate affixed to the appliance to determine its rated input (Btu/hr) and the size of the factory installed orifices.

IMPORTANT NOTE: Before installing an orifice, check the side or face of the orifice for the drill number to ensure that it is the appropriate size.

12. Install the appropriate LP/Propane gas burner orifices (2) into the gas manifold assembly (7).

NOTE: To prevent cross threading, hand tighten the orifices (2) into the gas manifold assembly (6) until snug, then tighten with a wrench.

WARNING:

Do not use Teflon tape or pipe joint compound on the orifice threads. The hole in the orifice may become blocked and cause fire, explosion, property damage, carbon monoxide poisoning, personal injury, or death.

13. Reinstall the gas manifold assembly (7) to the burner assembly (9) with the 4 screws (8), that were removed earlier. **NOTE:** It is important that the center of the orifices (2) are aligned with the center of the burners (1).
14. Reconnect the gas piping to the gas valve inlet (5).
15. Reconnect the wires to the gas valve terminals (3).

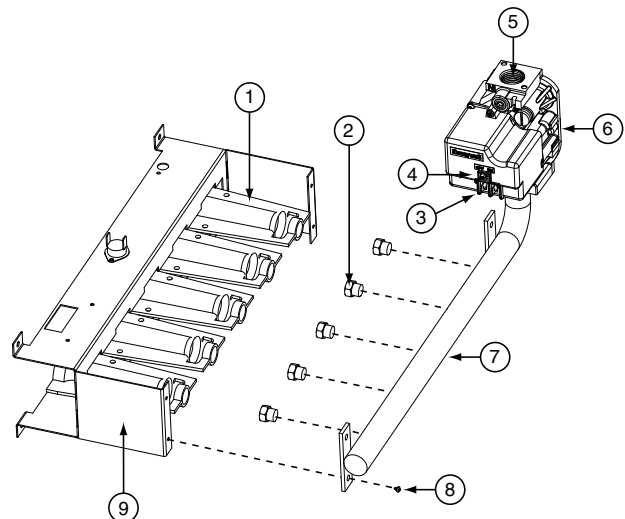

Figure 1. Burner & Manifold Assembly

Model VR9205Q

IMPORTANT NOTE: When converting to LP/Propane gas from natural gas, the springs from gas valve must be replaced by the larger springs from the kit. The LP/Propane springs for both HIGH & LOW fire are the same size, shape and color.

1. Remove the HIGH fire cap screw. See Figure 5.
2. Remove and discard the HIGH fire adjustment screw from the gas valve.
3. Remove the spring from the gas valve and discard.
4. Install a larger spring from the conversion kit.

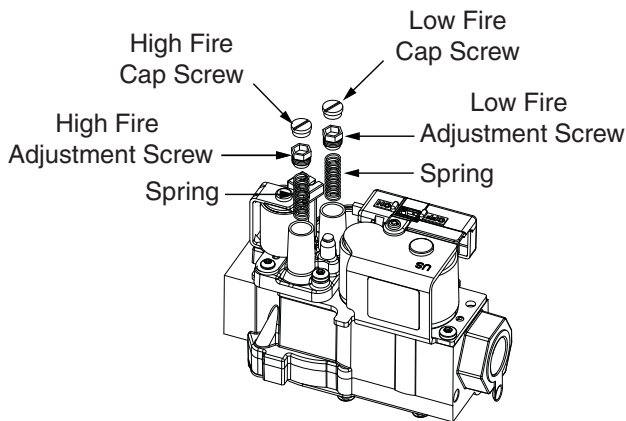

Figure 5. Pressure Regulator Spring & Adjustment Screw Removal

5. Install a new adjusting screw from the kit.
6. Repeat steps 1 - 6 for replacement of the LOW fire spring and adjustment screw.
7. Check and adjust the regulator setting. See Gas Pressure Adjustment Section.
8. Reinstall the cap screws on the HIGH and LOW regulators. Plastic replacement cap screws are provided in the conversion kit.
9. Affix the label from the conversion kit to the gas valve.

GAS PRESSURE ADJUSTMENT

Measuring the Supply Gas Pressure

1. Turn OFF the gas supply at the manual valve located on the outside of the unit.
2. Using a 3/16" Allen wrench, remove the plug from the inlet pressure tap (INLET side of gas valve). See Figure 6.
3. Install an 1/8" NPT pipe thread fitting, that is compatible with a Manometer or similar pressure gauge.
4. Connect the Manometer or pressure gauge to the Inlet Pressure Tap.
5. Turn ON the main gas supply at the manual valve.
6. Check and adjust the incoming gas line pressure to 11.0-14.0 inches Water Column for LP/Propane gas.
7. Turn OFF the gas supply at the manual valve.
8. Disconnect the Manometer or pressure gauge.
9. Remove the NPT fitting and reinstall the INLET pressure tap plug. Hand tighten the plug first to prevent cross-threading. Tighten with 3/16 Allen wrench.

Lighting & Adjustment of the Appliance

WARNING:

FIRE OR EXPLOSION HAZARD

Failure to follow safety warnings exactly could result in serious injury or property damage.

Never test for gas leaks with an open flame. Use a commercially available soap solution made specifically for the detection of leaks to check all connections. A fire or explosion may result causing property damage, personal injury or loss of life.

1. Turn ON the manual gas valve, located on the outside of the unit to the ON position.
2. Check all gas connections for leaks with a soap and water solution. If the solution bubbles there is a gas leak which must be corrected.
3. Turn on the electrical power to the appliance.
4. Place the gas valve ON/OFF switch/knob to the ON position. See Figure 6.

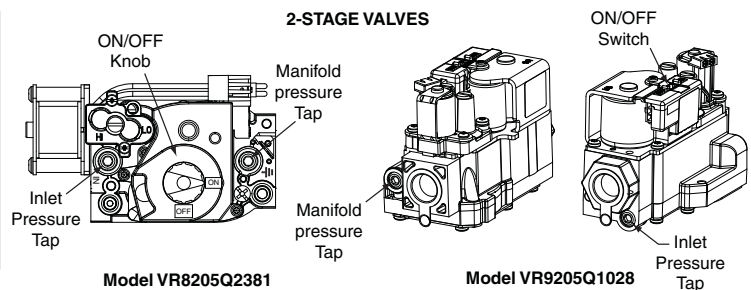

- Set the thermostat to a point above room temperature to begin the heating cycle of the furnace.
- Check that the furnace ignites and operates properly. Refer to the installation instructions provided with the unit for the normal operating sequence.
- After ignition, visually inspect the burner assembly to ensure that the flame is drawn directly into the center of the heat exchanger tube. In a properly adjusted burner assembly, the flame color should be blue with some light yellow streaks near the outer portions of the flame.

NOTE: The ignitor may not ignite the gas until all air is bled from the gas line. If the ignition control locks out, turn the thermostat to its lowest setting and wait one minute then turn the thermostat to a point above room temperature and the ignitor will try again to ignite the main burners. This process may have to be repeated several times before the burners will ignite. After the burners are lit, check all gas connections for leaks again with the soap and water solution.

Measuring the Manifold Pressure

The manifold pressure must be measured by installing a pressure gauge (Manometer, Magnehelic Meter, etc.) to the outlet end of the gas valve as follows:

- Turn off all electrical power to the appliance.
- Shut OFF the gas supply at the manual shutoff valve located outside of the appliance.
- Using a 3/16" Allen wrench, remove the manifold pressure tap plug located on the outlet side of the gas valve. See Figure 6 (page 5).
- Install an 1/8" NPT pipe thread fitting, that is compatible with a Manometer or similar pressure gauge.
- Connect the Manometer or pressure gauge to the manifold pressure tap.
- Set the room thermostat above room temperature to start the furnace.
- Allow the furnace to operate for 3 minutes and then check the manifold pressure. Compare the measured value with the value shown in Table 2 (page 3). If the manifold pressure is not set to the appropriate pressure, then it must be adjusted.

Adjusting the Manifold Pressure

NOTE: Adjustments must be made to both LOW & HIGH fire settings when converting two-stage gas valves. Refer to Table 2 for manifold pressures.

- Single stage gas valve: Remove the cap screw from the top of the gas valve regulator. See Figure 2 (page 4) for VR8205S2890 or VR8215S1206 models.
2-stage gas valve: For VR8205Q2381 models, remove the plastic cap covering the adjustment screws (Figure 4 page 4). For VR9205Q1028 models, remove the cap screw (Figure 5, page 5).
- Using a screwdriver or allen wrench (where appropriate), slowly turn the adjustment screw till the appropriate manifold pressure listed in Table

2 is achieved. See Figure 2 for VR8205S2890 or VR8215S1206 models. See Figure 4 for VR8205Q2381 models or Figure 5 for VR9205Q1028 models.

NOTE: Turning the screw clockwise increases the pressure, turning the screw counter-clockwise decreases the pressure. To prevent the screw from backing all the way out from the valve, turn the screw slowly.

- Replace and tighten the cap screw or the plastic cap over the adjustment screw.

Removing the Manometer/Pressure Gauge

After the manifold pressure is properly adjusted, the Manometer or pressure gauge must be removed from the gas valve.

- Turn the thermostat to its lowest setting.
- Turn OFF the main gas supply to the unit at the manual shut-off valve, which is located outside of the unit.
- Turn OFF all of the electrical power supplies to the unit.
- Remove the pressure gauge adapter from the gas valve and replace it with the 1/8" NPT manifold pressure plug that had been removed earlier. **NOTE:** Make sure the plug is tight and not cross-threaded.
- Turn ON the electrical power to the unit.
- Turn ON the main gas supply to the unit at the manual shut-off valve.

COMPLETING THE CONVERSION

WARNING:

Do not alter or remove the original rating plate from the furnace.

- Attach the following labels:
 - The conversion warning label (P/N 703935) should be affixed to the outside of the unit door.
 - The conversion information label (P/N 703942) should be affixed near the rating plate on the inside of the control area.
 - The gas valve conversion label should be affixed on the gas valve.

NOTE: Each label should be prominently visible after installation.

- Reinstall the appliance door.
- Run the appliance through 3 complete cycles to assure proper operation.