

R4184D; R8184G,M,N,P Protectorelay® Oil Primary Controls

INSTALLATION INSTRUCTIONS

APPLICATION

The intermittent ignition R4184D and R8184G,M,N,P Oil Primary Controls operate the oil burner, oil valve (if desired) and the ignition transformer in response to a call for heat from the thermostat.

The R8184M also provides automatic, nonrecycling control of cooling systems and low voltage thermostat.

The R8184P provides 15-second valve on delay and selectable 0-, 2-, 4-, 6-minute blower off delay for hydronic and warm air systems. Select models have 30-minute blower off delay timing.

All models use the C554A Cadmium Sulfide (cad cell) Flame Detector to monitor the burner flame and shut down the system on ignition failure or on flame failure during the run cycle. A manual reset button is provided to reset the safety switch after lockout. Clock thermostats (not available on R8184P) that power the clock through the primary control transformer lose time during lockout unless backup batteries are installed.

All models (except the R8184G1310 and R8184G1328) are Underwriters Laboratories Inc. component recognized and meet flammability test requirements for a final enclosure.

NOTE: R8184P is intended for use on oil burning appliances that do not require a safety rated prepurge and postpurge function as defined in UL 296. The valve on delay and blower off delay in this control are only intended to help establish draft and reduce oil after drip-related problems.

INSTALLATION

When Installing this Product...

1. Read these instructions carefully. Failure to follow instructions can damage the product or cause a hazardous condition.
2. Check ratings given in the instructions and on the product to make sure the product is suitable for your application.
3. Make sure the installer is a trained, experienced service technician.
4. After completing the installation, use these instructions to check out the product operation.



CAUTION

1. Disconnect the power supply before beginning installation to prevent electrical shock or equipment damage.
2. Be sure the combustion chamber is free of oil or oil vapor before starting the system.

Location

1. Mount on a 4 x 4 junction box, directly on the main burner housing or inside the appliance cabinet. See Fig. 1.
2. Be sure that operating temperatures are between -40°F and +130°F (-40°C and +54°C). Select R8184G,P models have a maximum temperature of 150°F (66°C), but must be mounted parallel to the ground to achieve 150°F (66°C). See Fig. 2.

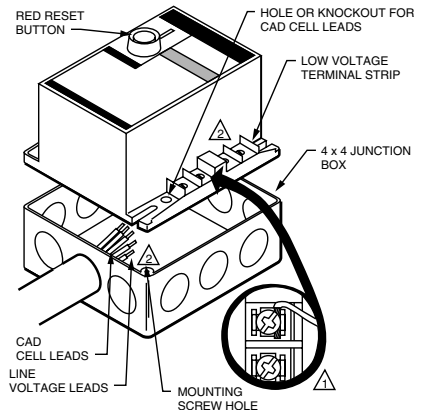

- ▲ STRIP WIRES 3/8 in. (9.5 mm); INSERT FROM SIDE, ABOVE OR BELOW.
- ▲ T-T TERMINALS ON R8184G; T1-T2 TERMINALS ON R8184N.
- ▲ ATTACH WITH NO. 8 MOUNTING SCREWS (OBTAINED LOCALLY).

M1643C

Fig. 1. Wire and mount 130°F (54°C) maximum ambient temperature oil primary control.



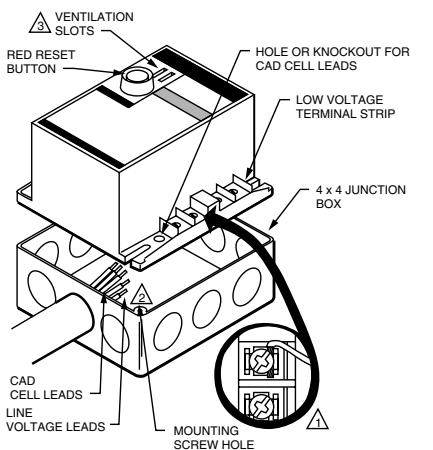

- ⚠ STRIP WIRES 3/8 in. (9.5 mm); INSERT FROM SIDE, ABOVE OR BELOW.
- ⚠ ATTACH WITH NO. 8 MOUNTING SCREWS (OBTAINED LOCALLY).
- ⚠ VENTILATION SLOTS ONLY AVAILABLE ON SELECT MODELS. M1642C

Fig. 2. Wire and mount 150°F (66°C) maximum ambient temperature oil primary control.

Line Voltage Wiring Connections

Wiring must comply with all local codes and ordinances.

- 1 Be sure all line voltage connections are in a wiring enclosure such as a junction box or the appliance wiring compartment.
- 2 Make the line voltage connections as shown in Fig. 3 through 9.
- 3 Splice the leads with solderless connectors.

IMPORTANT

Do not exceed the load ratings listed in Table 1.

- 4 Thread the line voltage cad cell leads through the hole on the bottom of the low voltage terminal strip. See Fig. 1 or 2.

Table 1. Load relay contact ratings.

Model	120 Vac		240 Vac	
	AFL	ALR	AFL	ALR
R4184D; R8184G,M,N (45-second models)	7.4A	44.4A	3.7A	22.2A
R8184P (15-, 30-, 45-second models)	7.4A	44.4A	NA	NA
R8184G (15- and 30-second models)	10.0A	60.6A	5.0A	30.0A

Alarm Contact Rating: 25 VA at 24V, 50/60 Hz.

Mounting

- 1 If necessary, use the control as a template to mark and drill new mounting holes.
- 2 Mount the control using no. 8 screws (obtained locally).

Low Voltage Wiring Connections

After mounting, make low voltage connections to screw terminals as follows:

- R4184D—connect the cad cell leads to the F-F terminals. See Fig. 3.
- R8184G—connect the cad cell leads to the F-F terminals and thermostat leads to the T-T terminals. See Fig. 4 and 5.
- R8184M—connect the cad cell leads to the F-F terminals and connect remaining low voltage wiring as shown in Fig. 6.

NOTE: The Y and G terminals are *not* connected to the internal circuitry of the R8184M. The Y and G terminals are provided to simplify the connections of the cooling equipment.

- R8184N—connect the cad cell leads to the F₁-F₂ terminals and thermostat leads to the T₁-T₂ terminals. See Fig. 7.
- R8184P hydronic hookup. Connect the cad cell leads to the F-F terminals. See Fig. 8.
- R8184P warm air hookup. Connect the card cell leads to the F-F terminals and the thermostat leads to the R-W terminals. See Fig. 9.

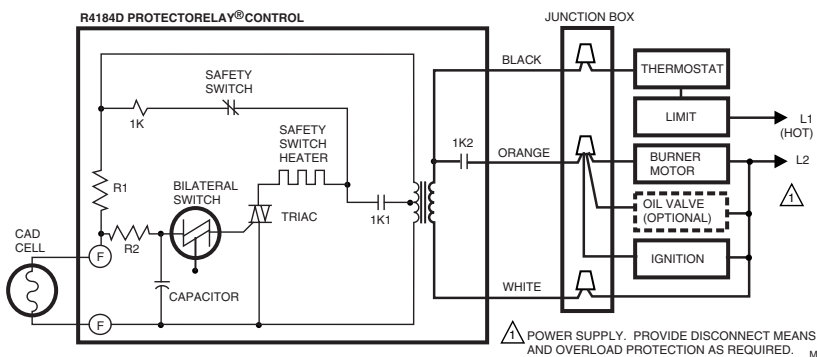

Fig. 3. Typical hookup for R4184D.

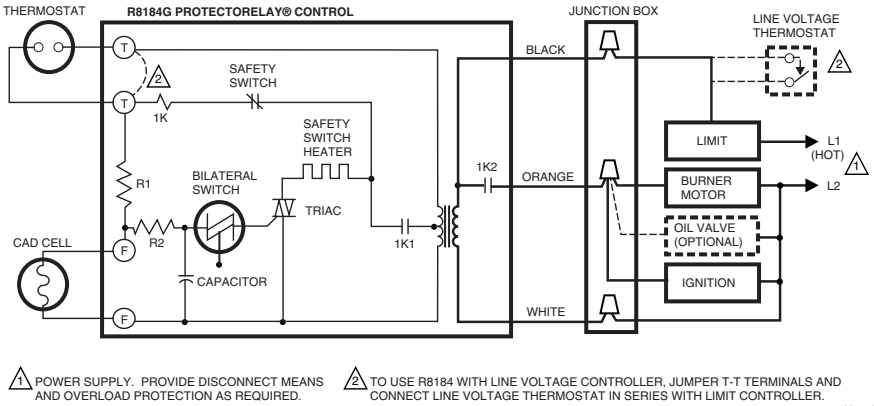

Fig. 4. Typical hookup for R8184G.

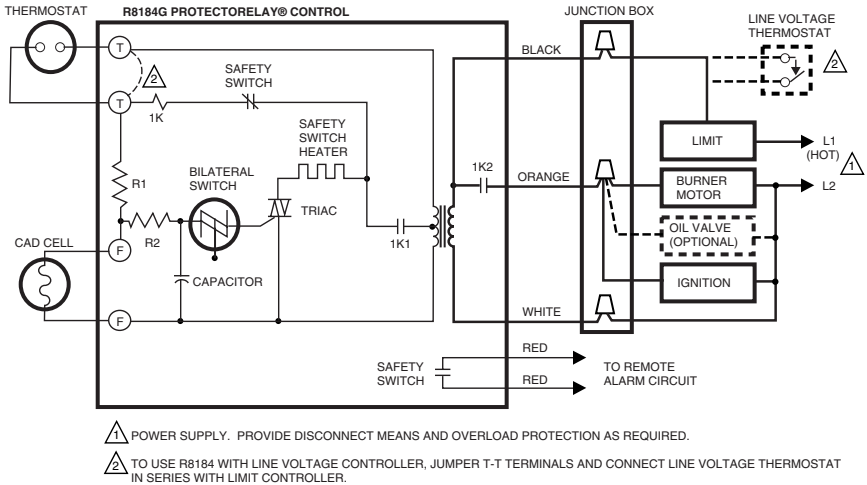

Fig. 5. Typical hookup for R8184G with dry contacts for remote alarm.

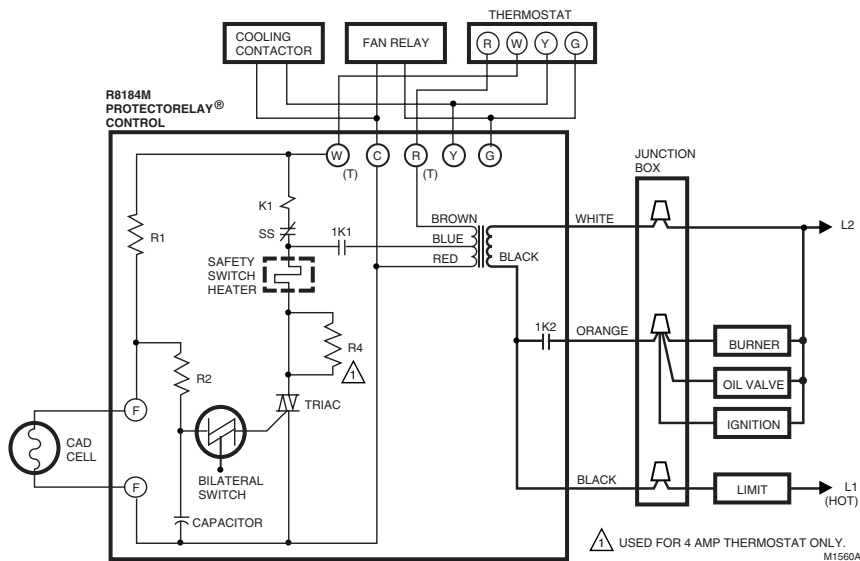

Fig. 6. Typical hookup for R8184M.

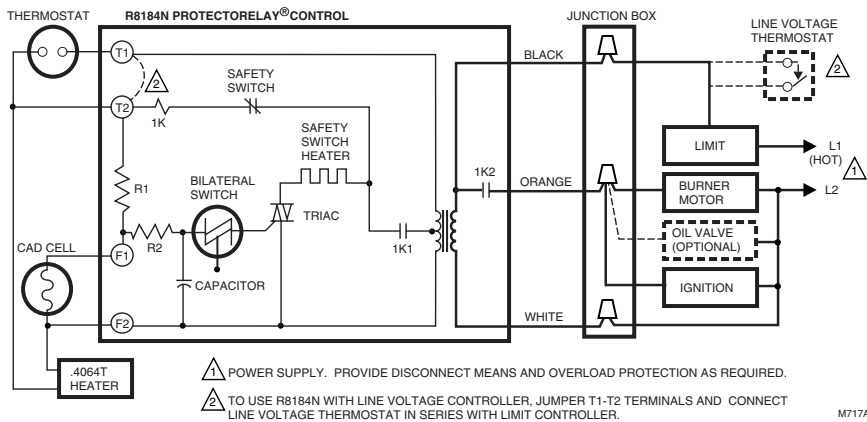
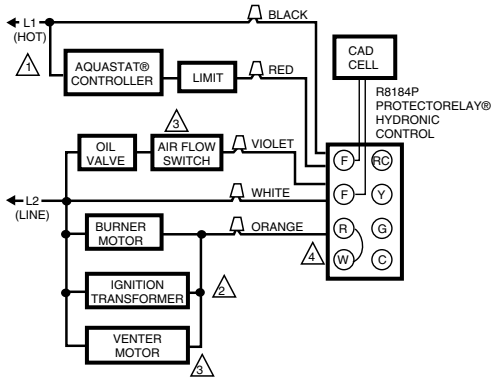
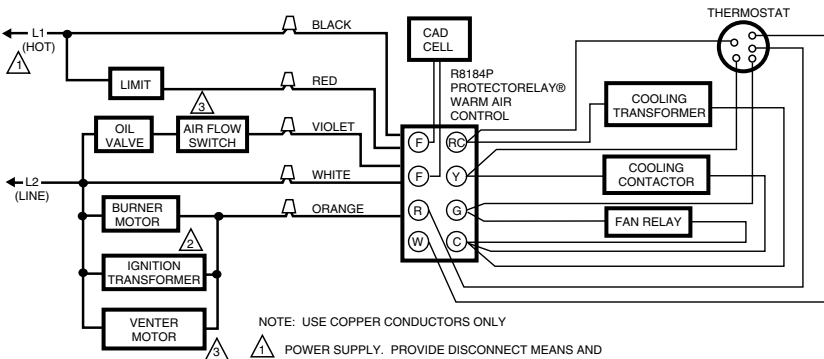

Fig. 7. Typical hookup for R8184N.



- 1 POWER SUPPLY. PROVIDE DISCONNECT MEANS AND OVERLOAD PROTECTION AS REQUIRED.
 - 2 IGNITION TRANSFORMER CAN BE CONNECTED TO VALVE OR BURNER MOTOR.
 - 3 OMIT ON SYSTEMS WITHOUT POWER VENTING.
 - △ JUMPER R-W.
- M10022

Fig. 8. Typical hydronic hookup for R8184P.



- NOTE: USE COPPER CONDUCTORS ONLY
- 1 POWER SUPPLY. PROVIDE DISCONNECT MEANS AND OVERLOAD PROTECTION AS REQUIRED.
 - 2 IGNITION TRANSFORMER CAN BE CONNECTED TO VALVE OR BURNER MOTOR.
 - 3 OMIT ON SYSTEMS WITHOUT POWER VENTING.
- M10021

Fig. 9. Typical warm air hookup for R8184P.

CHECKOUT

Start System

WARNING

FIRE OR EXPLOSION HAZARD CAN CAUSE PROPERTY DAMAGE, SEVERE INJURY OR DEATH

Be sure the combustion chamber is free of oil or oil vapor before starting the system.

- 1 Push in and release the red reset button.
- 2 Open the hand valve in the oil supply line.
- 3 Make sure the system is powered. Check the circuit breaker or fuse and close the system switch, if provided.

NOTE: If the safety switch has just locked out, the safety switch may need a minute to cool down before it can be reset.

- 4 Set thermostat to call for heat.
- 5 Burner should light and operate until a call for heat ends.

Check Safety Features

Simulate flame failure:

- 1 Follow the starting procedure to turn on the burner.
- 2 Close the hand valve in the oil supply line.
- 3 Safety switch should lock out in safety switch timing indicated on the label (15, 30 or 45 seconds). Alarm switch contacts close to initiate alarm on models with remote dry contacts. Ignition and motor should stop and oil valve should close.
- 4 Push red reset button to reset safety switch.

Simulate ignition failure:

- 1 Follow the starting procedure to turn on the burner, but do not open the oil supply hand valve.
- 2 Safety switch should lock out in safety switch timing indicated on the label. Alarm switch contacts close to initiate alarm on models with remote dry contacts. Ignition and motor should stop and oil valve should close.
- 3 Push the red reset button to reset the safety switch.

Simulate power failure:

- 1 Follow the starting procedure to turn on the burner.
- 2 With the burner running, turn off the power to the system by tripping the circuit breaker or removing the fuse.
- 3 Burner should stop.
- 4 Restore power. Burner should start.

If system does not operate as described, go to the TROUBLESHOOTING AND MAINTENANCE section.

TROUBLESHOOTING AND MAINTENANCE

IMPORTANT

1. Only a trained, experienced service technician should perform the troubleshooting procedure.
2. This control contains no field-replaceable parts. Do not attempt to take it apart. Replace the entire control if operation is not as described.

Preliminary Steps

- 1 Check the wiring connections and power supply. Make sure power is on to the controls, burner motor and ignition transformer.
- 2 Make sure the limit control is closed.

Check Oil Primary Relay

NOTE: You will need an insulated jumper wire with both ends stripped.

- 1 Disconnect cad cell leads from F-F or F₁-F₂ terminals.
- 2 Reset the safety switch and set the thermostat to call for heat. Burner should start.
- 3 Within the safety switch timing, use insulated wire to jumper F-F or F₁-F₂ terminals. Burner should continue to run.
- 4 After the safety switch timing, remove the jumper. Burner should shut down in the safety switch timing.
- 5 If the operation is not as described, replace the oil primary control.

Check Cad Cell

- 1 Disconnect the power at the system switch, circuit breaker, or fuse.
- 2 Disconnect cad cell leads from F-F or F₁-F₂ terminals.
- 3 Clean the cell face with a soft cloth.
- 4 Make sure the cell is seated securely in the socket. Be careful not to disturb the socket position.
- 5 Reconnect the cad cell leads to F-F or F₁-F₂ terminals.
- 6 Reset the safety switch, turn on the power and set the thermostat to call for heat.
- 7 If burner does not operate or if safety switch trips, replace the cad cell. Order Honeywell part no. 130367 Cad Cell.

Honeywell

Automation and Control Solutions

Honeywell International Inc.
1985 Douglas Drive North
Golden Valley, Minnesota 55422

Honeywell Limited-Honeywell Limitée
35 Dynamic Drive
Scarborough, Ontario M1V 4Z9

