



SUBMITTAL DATA SHEET

One Way Cassette Heat Pump System

Location: _____
 Engineer: _____
 Submitted to: _____
 Submitted by: _____
 Reference: _____

Approval: _____
 Date: _____
 Construction: _____
 Unit #: _____
 Drawing #: _____

Set Code	22022510004783
Indoor unit code	22022511003917
Outdoor unit code	22022016016162
Set Model	
Indoor unit model	MIU-A09CO-2
Outdoor unit model	MOU-A09H-2
Certified	
AHRI	
UL	
	

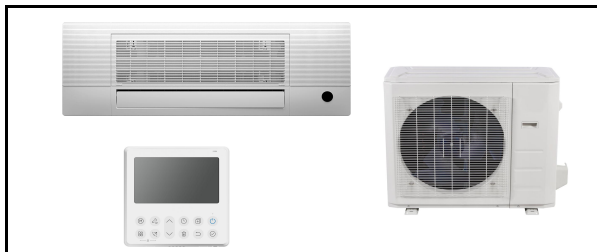

SYSTEM PERFORMANCE DATA

Power supply		
Normal Operational Voltage	(V, Ph, Hz)	208/230V, 1Ph, 60Hz
Voltage Range	(V)	187-253
Electrical		
Minimum circuit ampacity(Outdoor)	(A)	15.0
Max.fuse(Outdoor)	(A)	15.0
Connection wiring		14*4 AWG
Cooling		
Capacity	(Btu/h)	9000(3600~12200)
Power Input	(W)	692(282~1150)
Current	(A)	3.10(1.4~5.2)
SEER2	(Btu/W)	24.0
EER2	(Btu/W)	13.0
Heating		
Capacity	(Btu/h)	10900(4800~14000)
Power Input	(W)	968(391~1400)
Current	(A)	5.24(2.1~6.3)
HSPF2-4	(Btu/W)	12.4
HSPF2-5	(Btu/W)	9.5
COP	W/W	3.30
Heat at 17F(H32)	(Btu/h)	9800
Heat at 5F(H42)	(Btu/h)	10500
COP at 5F(H42)	W/W	1.80

REFRIGERANT PIPE DATA

Throttle type	Indoor unit	N/A
	Outdoor unit	EXV
Design pressure	(PSIG)	550/340
Refrigerant Type		R410A
Refrigerant charge	oz	41.62
Refrigerant precharge	(ft)	25.0
	(m)	7.5
Additional charge for each ft	(oz/ft)	0.16
Additional charge for each m	(g/m)	15.0
Liquid side/ Gas side(indoor)	(inch)	1/4" / 3/8"
	(mm)	6.35/9.52
Liquid side/ Gas side(outdoor)	(inch)	1/4" / 3/8"
	(mm)	6.35/9.52
Max. pipe length	(ft)	82.0
	(m)	25.0
Max. difference in level	(ft)	32.8
	(m)	10.0
Connection method		Flared
Indoor(cooling)	(Deg. °F)	60~90
	(Deg. °C)	16~32
Indoor(heating)	(Deg. °F)	32~86
	(Deg. °C)	0~30
Outdoor(cooling)	(Deg. °F)	-22~122
	(Deg. °C)	-30~50
Outdoor(heating)	(Deg. °F)	-22~75
	(Deg. °C)	-30~24

INDOOR UNIT DATA

Indoor fan motor		
Model		ZKFN-30-8-43
Qty		1
Input	(W)	/
Output	(W)	30.0
RLA	(A)	0.80
Speed(Hi/Mi/Lo)	(r/min)	1024/944/784
Air flow & Noise level		
Indoor air flow (Hi/Med/Lo) (No duct)	(CFM)	341.18/294.12/258.82/235.29
Indoor noise level (Hi/Med/Lo)	[dB(A)]	37.5/35.5/31
Dehumidification	(L/H)	1.02
Indoor unit		
Dimension (WxDxH)	(inch)	50.31x13.19x8.98
	(mm)	1278x335x228
Packing(WxDxH)	(inch)	57.60x22.48x22.64
	(mm)	1463x571x575
Net/Gross weight	(lbs.)	43.87/81.35
	(kg)	19.9/36.9

OUTDOOR UNIT DATA

Compressor		
Type		ROTARY
Model		KTN110D42UFZ
Brand		GMCC
Capacity	(Btu/h)	11823
Input	(W)	885
Rated current (RLA)	(A)	8.8
Refrigerant oil/oil charge	(ml)	VG74/350
Outdoor fan motor		
Model		ZKFN-34-10-1
Qty		1
Input	(W)	/
Output	(W)	34.00
RLA	(A)	0.42
Speed	(r/min)	850/680/450
Air flow & Noise level		
Outdoor air flow (Max.)	(CFM)	1323.5
Outdoor noise level	[dB(A)]	55.5
Outdoor unit		
Dimension (WxDxH)	(inch)	31.69x12.99x21.81
	(mm)	805x330x554
Packing (WxDxH)	(inch)	36.02x14.57x24.21
	(mm)	915x370x615
Net/ Gross weight	(lbs.)	74.07/80.25
	(kg)	33.6/36.4

Indoor unit dimension

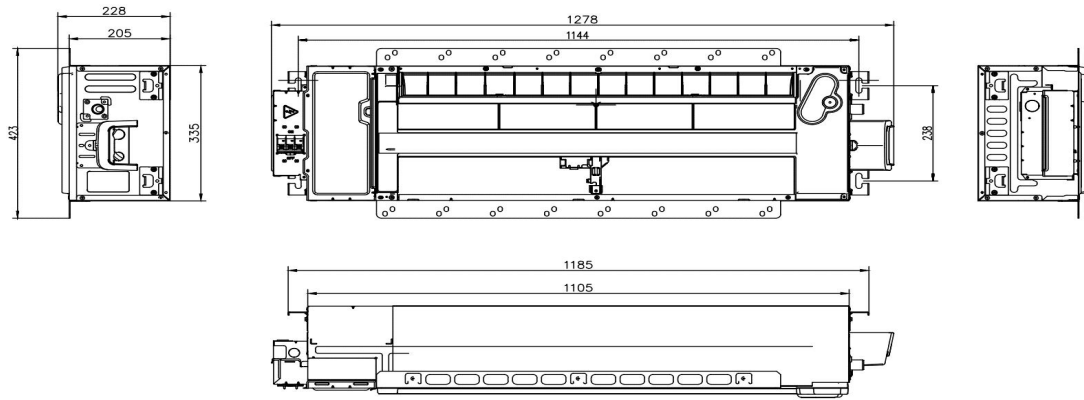

Outdoor unit dimension

