



SUBMITTAL DATA SHEET

Wall Mounted Heat Pump System	
Location: _____	Approval: _____
Engineer: _____	Date: _____
Submitted to: _____	Construction: _____
Submitted by: _____	Unit #: _____
Reference: _____	Drawing #: _____

Set Code	22022010018017
Indoor unit code	22022011016723
Outdoor unit code	22022016015900
Set Model	
Indoor unit model	MIU-A18W-2
Outdoor unit model	MOU-A18H-2
Certified	
AHRI	
UL	



SYSTEM PERFORMANCE DATA

Power supply		
Normal Operational Voltage	(V, Ph, Hz)	208/230V, 1Ph, 60Hz
Voltage Range	(V)	187-253
Electrical		
Minimum circuit ampacity(Outdoor)	(A)	20.0
Max.fuse(Outdoor)	(A)	25.0
Connection wiring		14AWG*4
Cooling		
Capacity	(Btu/h)	18000(8400~20200)
Power Input	(W)	1385(360~1860)
Current	(A)	8.9(2.5~9)
SEER2	(Btu/W)	22.0
EER2	(Btu/W)	13.0
Heating		
Capacity	(Btu/h)	18000(12000~23000)
Power Input	(W)	1575(815~2170)
Current	(A)	9.2(5.3~9.5)
HSPF2-4	(Btu/W)	10.6
HSPF2-5	(Btu/W)	7.9
COP	W/W	3.35
Heat at 17F(H32)	(Btu/h)	11100
Heat at 5F(H42)	(Btu/h)	17200
COP at 5F(H42)	W/W	1.89

REFRIGERANT PIPE DATA

Throttle type	Indoor unit	N/A
	Outdoor unit	EXV
Design pressure	(PSIG)	550/340
Refrigerant Type		R410A
Refrigerant charge	oz	65.26
Refrigerant precharge	(ft)	25.0
	(m)	7.5
Additional charge for each ft	(oz/ft)	0.16
Additional charge for each m	(g/m)	15.0
Liquid side/ Gas side(indoor)	(inch)	1/4"/1/2"
	(mm)	6.35/12.7
Liquid side/ Gas side(outdoor)	(inch)	1/4"/1/2"
	(mm)	6.35/12.7
Max. pipe length	(ft)	98.4
	(m)	30.0
Max. difference in level	(ft)	65.6
	(m)	20.0
Connection method		Flared
Indoor(cooling)	(Deg. °F)	60~90
	(Deg. °C)	16~32
Indoor(heating)	(Deg. °F)	32~86
	(Deg. °C)	0~30
Outdoor(cooling)	(Deg. °F)	-22~122
	(Deg. °C)	-30~50
Outdoor(heating)	(Deg. °F)	-22~75
	(Deg. °C)	-30~24

INDOOR UNIT DATA

Indoor fan motor		
Model		ZKFP-58-8-1-5
Qty		1
Input	(W)	58.00
Output	(W)	58.0
RLA	(A)	0.3
Speed(Hi/Mi/Lo)	(r/min)	1120/950/700
Air flow & Noise level		
Indoor air flow (Hi/Med/Lo) (No duct)	(CFM)	760.59/530.59/458.82/382.35
Indoor noise level (Hi/Med/Lo)	[dB(A)]	46/40/25
Dehumidification	(L/H)	1.35
Indoor unit		
Dimension (WxDxH)	(inch)	42.60x9.21x13.27
	(mm)	1082x234x337
Packing(WxDxH)	(inch)	45.47x16.34x12.40
	(mm)	1155x415x315
Net/Gross weight	(lbs.)	29.54/37.48
	(kg)	13.4/17

OUTDOOR UNIT DATA

Compressor		
Type		Twin-ROTARY
Model		KTM240D43UKT
Brand		GMCC
Capacity	(Btu/h)	25931
Input	(W)	2045
Rated current (RLA)	(A)	14.25
Refrigerant oil/oil charge	(ml)	ESTER OIL VG74 620
Outdoor fan motor		
Model		ZKFN-80-8-3
Qty		1
Input	(W)	/
Output	(W)	80
RLA	(A)	0.8
Speed	(r/min)	810/720
Air flow & Noise level		
Outdoor air flow (Max.)	(CFM)	1765
Outdoor noise level	[dB(A)]	58.0
Outdoor unit		
Dimension (WxDxH)	(inch)	35.04x13.46x26.50
	(mm)	890x342x673
Packing (WxDxH)	(inch)	39.17x15.67x29.13
	(mm)	995x398x740
Net/ Gross weight	(lbs.)	100.97/108.03
	(kg)	45.8/49

Indoor unit dimension

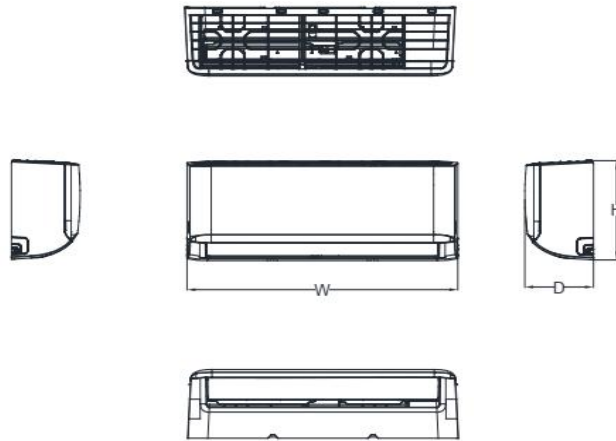

Capacity	Body Code	W(mm/inch)	D(mm/inch)	H(mm/inch)
6K~11K	A	729/28.7	200/7.87	292/11.5
8K~14K	B	802/31.57	200/7.87	295/11.61
12K~21K	C	971/38.23	228/8.98	321/12.64
18K~28K	D	1082/42.6	234/9.21	337/13.27
27K~36K	F	1259/49.57	283/11.14	362/14.25

Outdoor unit dimension

