



Submittal Form

Project Name:	
Location:	
Engineer:	
Submitted to:	
Submitted by:	
Reference:	

Approval:	
Date:	
Construction:	
Unit #:	
Drawing #:	

MODEL #	
INDOOR:	MEHSU-36CSC2
OUTDOOR:	MCHSU-36CSH2



ELECTRICAL			
Power supply	Ph-V-Hz	1-208/230-60	
Minimum Circuit Ampacity	A	30	
Maximum Fuse Size	A	50	

INDOOR UNIT DATA		
Indoor fan		MEHSU-36CSC2
Model		ZKFP-124-8-2
Brand		WELLING
Input	W	124
RLA	A	1.5
Speed(Hi/Mi/Lo)	r/min	720/630/560
Indoor air flow (Hi/Mi/Lo)	CFM	1095/958/809
Indoor noise level (Hi/Mi/Lo)	dB(A)	55/52/49

COOLING			
Capacity	Btu/h	36000(9800-42000)	
Input	W	NA	
Rated current	A	NA	
EER	Btu/w	9	
SEER	Btu/w	17.5	

INDOOR UNIT DIMENSIONS		
Dimension(WxDxH)	inch	33.07X33.07X9.65
Packaging (WxDxH)	inch	35.43X35.43X10.12
Net/Gross weight	lbs.	58.2/66.14

HEATING			
Capacity	Btu/h	38000(9800-42000)	
Input	W	NA	
Rated current	A	NA	
COP	A	3.68	
HSPF	W/W	10.5	
Low temperature heating capacity (5f)	Btu/h	16000	

OUTDOOR UNIT DATA		
Outdoor fan		MCHSU-36CSH2
Model		ZKFN-120-8-2
Brand		WELLING
Input	W	120
RLA	A	1
Speed	r/min	950
Outdoor air flow	CFM	2530
Outdoor noise level	dB(A)	66

COMPRESSOR		
Model		ATF310D43UMT
Type		ROTARY
Brand		GMCC
Input	W	2600
Rated Current (RLA)	A	22
Refrigerant Oil/Charge	ml	POE VG74/1000

OUTDOOR UNIT DIMENSIONS		
Dimension(WxDxH)	inch	37.2X16.1X31.9
Packaging (WxDxH)	inch	42.91X19.69X34.45
Net/Gross weight	lbs.	148.59/160.94

SYSTEM DATA		
Design pressure	MPa	550/340 PSIG
Refrigerant	oz	R410A/108
Refrigerant precharge	ft	25
Additional charge per ft.	oz	0.161
Liquid	mm(in)	9.52(3/8")
Gas	mm(in)	15.9(5/8")
Max. refrigerant pipe length	ft.	213
Max difference in level	ft.	98

OPERATION TEMPERATURE		
Indoor(cooling/ heating)	Deg. F	62-90/32-86
Outdoor(cooling/heating)	Deg. F	5-122/5-86

ACCESSORIES		
Wired Control	Model#	120G2
Installation Kit	Model#	Installation Kit 3
Piping Kit	Model#	PJX-3

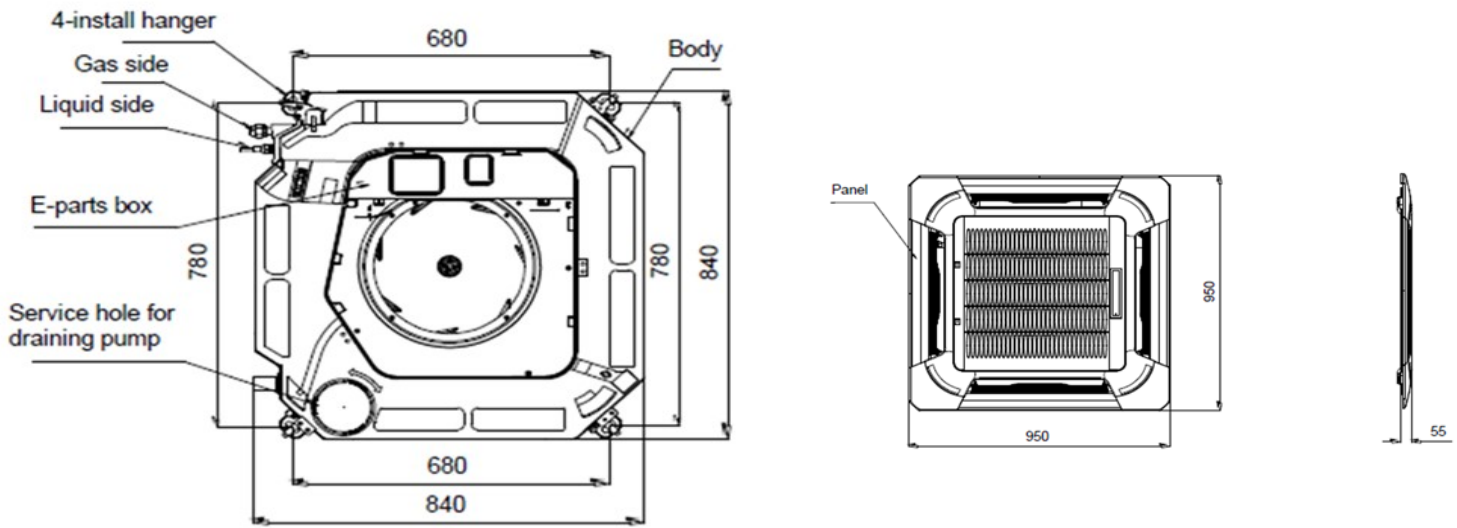

Dimensions	Width	Depth	Height
Inches	33 1/16	33 1/6	9 5/8

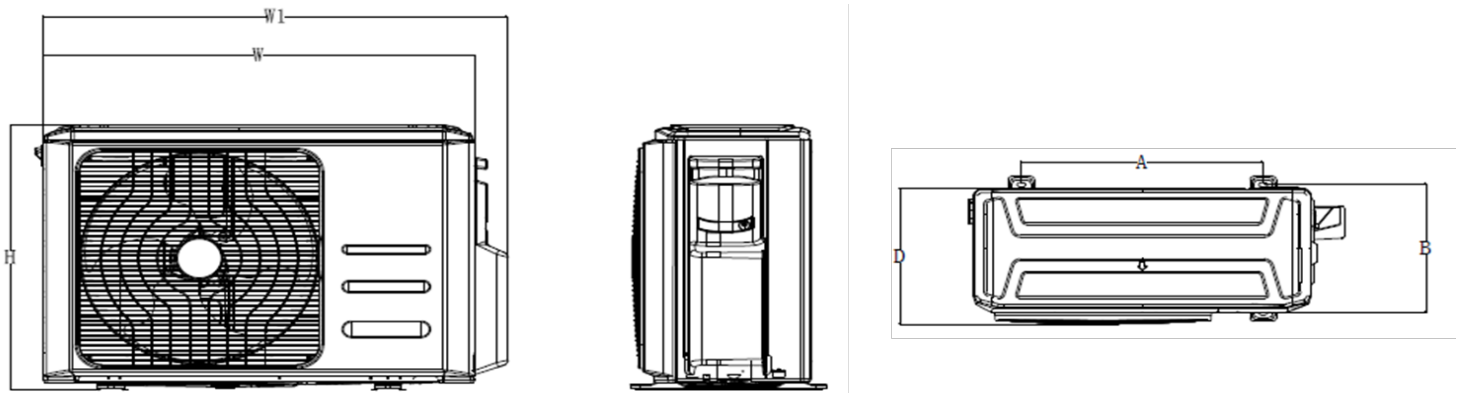

Dimensions	Width	Width 1	Depth	Height	A	B
Inches	37 1/4	40 5/8	16 1/8	31 7/8	26 1/5	15 7/8

Midea America Corp.

5 Sylvan Way, Parsippany, NJ 07054
 P: (973) 539-5330 - F: (973) 539-5336
www.midea.com/us